

Clayton Valley Shopping Center

5404-5458 Ygnacio Valley Road, Concord, CA 94521



5404-5458 Ygnacio Valley Road | Concord, CA 94521

LOCKEHOUSE

2099 Mt. Diablo Blvd., Suite 206
Walnut Creek, CA 94596
License #01784084



Regency
Centers.

Adria Giacomelli
SENIOR VICE PRESIDENT
925.997.2307
Adria@LockeHouse.com
License #01498795

Clayton Valley Shopping Center, Concord Site Plan



SUMMARY

Clayton Valley Shopping Center, Concord, CA 94521

Address: 5404-5458 Ygnacio Valley Road
Type: Grocery-Anchored Neighborhood Center
NNN: \$9.00 psf Annual Estimate 2017
GLA: 260,671 SF
Available: 1,655 - 70,273 SF Total
Zoning: Neighborhood Commercial (K17)
Seeking: Breakfast Restaurant, Sandwich Shop, Apparel and Accessories, Hair Salon, Sporting Goods & Retail



Suite 1408 Walk-Through Video:
<https://youtu.be/6VjBbvQQVA0>

Suite 020E Walk-Through Video:
<https://youtu.be/X6gBdx4QjwE>

Suite 012D Walk-Through Video:
<https://youtu.be/JEKxkfS1fKQ>

HIGHLIGHTS

- ◆ Dominant Grocery-Anchored Shopping Center boasting 260,000 SF
- ◆ Located at busy 4-way Signalized Intersection
- ◆ Boasting combined Traffic Counts of 42,000 Cars Per Day
- ◆ Excellent Access & Visibility from Clayton Road & Ygnacio Valley Road
- ◆ Featuring National Retailers including CVS, Grocery Outlet, Ross, Pet Food Express, Dollar Tree, Peet's Coffee, Jamba Juice, Round Table, Five Guys and so many more
- ◆ Seeking: Medical Office up to 3,000 SF
Studio Salon
Family-Friendly Restaurants
Korean/Indian/Greek Restaurants
Experiential Retail
Mattresses/Furniture
Financial Institutions

Clayton Valley Road Shopping Center is a proven 260,000 SF grocery-anchored center located at the 4-way, signalized intersection of Ygnacio Valley Road and Clayton Road, boasting combined traffic counts in excess of 42,000 cars per day. Clayton Valley benefits from a captive audience and offers patrons an extensive mix of national and regional tenants including CVS Pharmacy, Grocery Outlet, Ross, Petfood Express, Dollar Tree, Peet's Coffee, Jamba Juice and so many more.

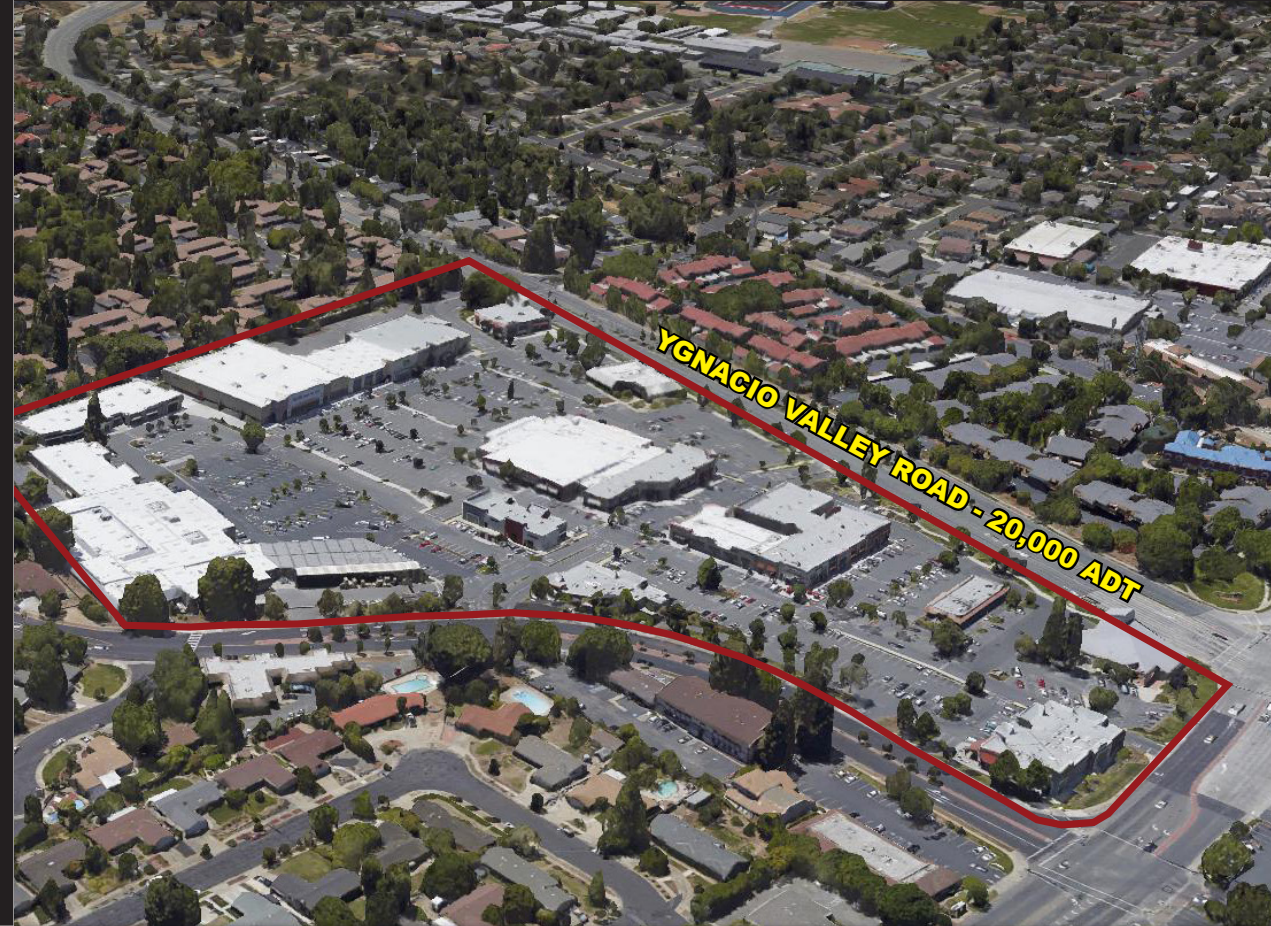

5404-5458 Ygnacio Valley Road | Concord, CA 94521

LOCKEHOUSE

2099 Mt. Diablo Blvd., Suite 206
Walnut Creek, CA 94596
License #01784084



Regency
Centers.

Adria Giacomelli
SENIOR VICE PRESIDENT
925.997.2307
Adria@LockeHouse.com
License #01498795

Clayton Valley Shopping Center, Concord Site Plan



CURRENT RETAILERS

AVAILABLE
 LEASED



0001	Ross Dress For Less	30,187 SF
0002	Grocery Outlet	14,000 SF
0003	CVS/Pharmacy	15,789 SF
005C	Sally Beauty Supply	1,680 SF
006C	Clayton Dance Academy	5,336 SF
011D	C2 Education Center	1,400 SF
012D	Former Tile Store	1,330 SF
013D	Clayton Frameworks	1,400 SF
014D	Fashion Cleaners	4,200 SF
021E	Five Guys Burgers & Fries	2,400 SF
022E	Massage Envy	2,660 SF
023-25E	The Company & Spa	2,450 SF
025E-1	Foresight Optometry	1,676 SF
026E	Jamba Juice	1,324 SF
027E	Panera Bread	3,145 SF
029B	Wingstop Restaurant	2,805 SF
029C	Clayton Valley Dental Care	1,985 SF
029E	Rose Liquors	1,517 SF
030E	Anytime Fitness	3,726 SF
032E	Concord Kung Fu Academy	3,915 SF
033E	Diamond Pue Water	1,346 SF
034E	Dollar Tree	10,313 SF
035E	Dickey's Barbeque Pit	1,740 SF
036E	AT&T	1,220 SF
037E	Gamestop	1,440 SF
038E	Sprint	1,528 SF
040E	Round Table Pizza	2,455 SF
041E	Banfield	2,440 SF
043E	T4	1,262 SF
044E	Sport Clips	970 SF
045E	Bronze Buddha	2,043 SF
047E	Yogurt Shack	1,500 SF
048E	I Brow Bar	850 SF
049E	TJ Nail Spa	1,650 SF
050E	T-Mobile	1,500 SF
1000	Burger King	3,359 SF
1200	Bank of America	5,124 SF
1300	Chase Bank	6,420 SF
1400	Peet's Coffee	1,703 SF
1402	Panda Express	2,456 SF
1406	Tachi Sushi Bar	2,456 SF
1408	Bella Ristorante	2,100 SF
1500	Pet Food Express	6,000 SF
1600	Guadalajara Grill	6,327 SF

AVAILABLE SPACE

5416-002C	3,170 SF	5420-12D	1,400 SF	5442-020E	5,760 SF
5416-002D	2,080 SF	5416-003C	2,080 SF	5442-027E	1,655 SF
5420-10D	2,800 SF	5416-004C	1,190 SF	5424-015D	70,273 SF

5404-5458 Ygnacio Valley Road | Concord, CA 94521

LOCKEHOUSE

2099 Mt. Diablo Blvd., Suite 206
Walnut Creek, CA 94596
License #01784084



Regency
Centers.

Adria Giacomelli
SENIOR VICE PRESIDENT
925.997.2307
Adria@LockeHouse.com
License #01498795

Clayton Valley Shopping Center, Concord

Building 5458 - Suite 1408, 2,100 SF



Suite 1408 (On Door #60) - Building 5458

Address: 5458 Ygnacio Valley Rd #60, Concord, CA 94521

Rent: \$3.50 PSF plus \$.77 NNN (2018 Estimate)

Size: 2,100 SF

- **You Tube** Walk-Thru Video: <https://youtu.be/6VjBbvQQVA0>
- Dimensions: 30' Frontage x 70' Depth
- Dominant Grocery-Anchored Shopping Center boasting 260,000 SF
- Located at busy 4-way Signalized Intersection
- Boasting combined Traffic Counts of 42,000 Cars Per Day
- Excellent Access & Visibility from Clayton Road & Ygnacio Valley Road
- Featuring National Retailers including CVS, Grocery Outlet, Ross, Pet Food Express, Dollar Tree, Peet's Coffee, Jamba Juice, Round Table, Five Guys and so many more

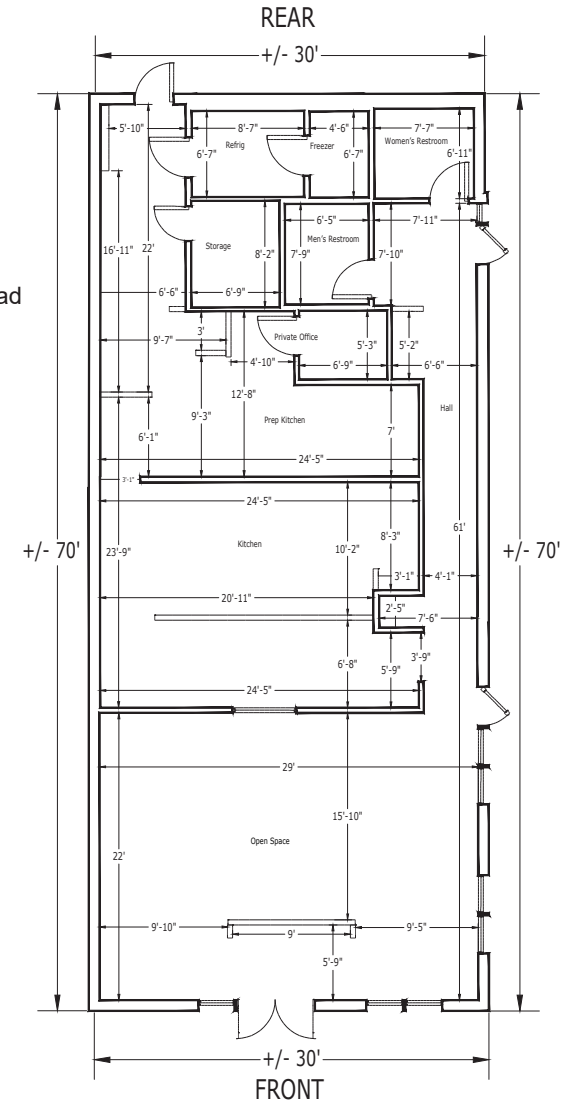

5404-5458 Ygnacio Valley Road | Concord, CA 94521

LOCKEHOUSE

2099 Mt. Diablo Blvd., Suite 206
Walnut Creek, CA 94596
License #01784084



Regency
Centers.

Adria Giacomelli
SENIOR VICE PRESIDENT
925.997.2307
Adria@LockeHouse.com
License #01498795

Clayton Valley Shopping Center, Concord

Building 5416 - 1,190 SF - 8,520 SF



Suite 002C (On Door #10) - Building 5416

Size: 3,170 SF

- Former Styles for Less
- Can be combined with adjacent suites
- 8,520 SF Dimensions are 90' x 86' in depth
- Situated between OSH and ROSS
- Parking convenient and abundant
- Double Door Entry



Suite 002D (On Door #20) - Building 5416

Size: 2,080 SF (Can Combine for Up To 5,250 SF)

- Former Diablo Yoga - Turnkey Condition
- Large Studio with 2 Points of Access
- 2 Restrooms towards Rear
- Lobby and Reception Desk
- Single Door Entry and Rear Access Door
- Dimensions: 19'.2" x 68'.11" approximately



Suite 003C (On Door #30) - Building 5416

Size: 2,080 SF (Different SF Options)

- Former Yoga with Studio in Rear and Mirrors on Wall
- 2 Restrooms - each with a Shower, Lockers, and Changing Area
- Single Door Entry and Rear Access Door
- Dimensions: 24' x 86'.8" approximately

Suites 2C, 2D, 3C, & 4C Can Be Combined

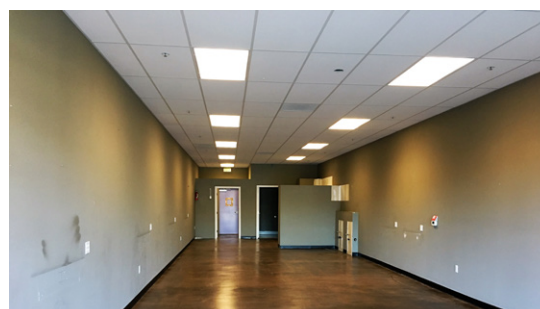

Suite 004C (On Door #40) - Building 5416

Size: 1,190 SF (Can Combine for Up To 5,250 SF)

- Former Hair Salon with Some Salon Infrastructure in Place
- Includes One Restroom, Sink and Plumbing for 2 Hair Washing Stations
- Single Door Entry and Rear Access Door
- Dimensions: 17' x 70'.2" approximately

Clayton Valley Shopping Center, Concord

Building 5442 - Suite 020E, 5,760 SF (Can Be Demised)



Suite 020E (On Door #90) - Building 5442 Size: 5,760 SF

- **YouTube** Walk-Thru Video: <https://youtu.be/X6gBdx4QjwE>

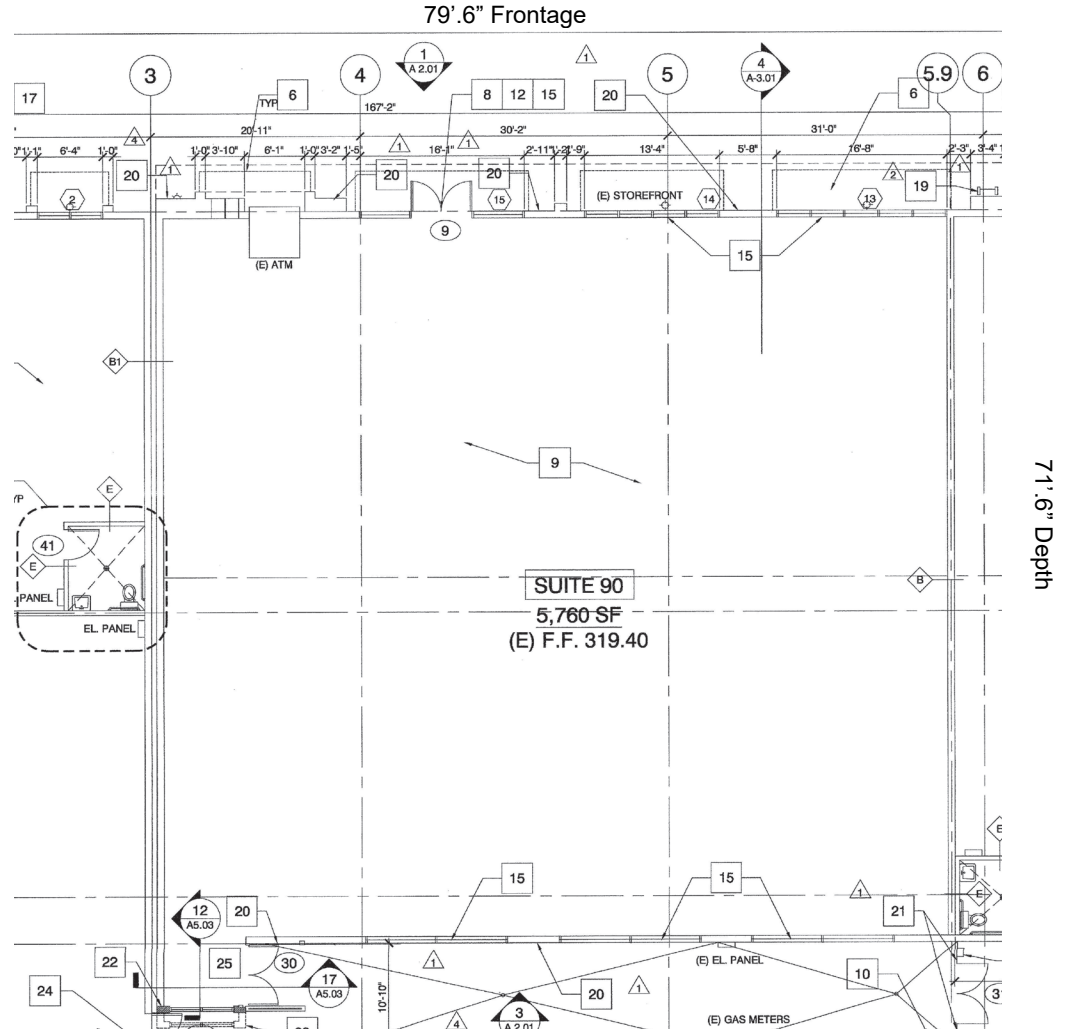

5404-5458 Ygnacio Valley Road | Concord, CA 94521

LOCKEHOUSE

2099 Mt. Diablo Blvd., Suite 206
Walnut Creek, CA 94596
License #01784084



Regency
Centers.

Adria Giacomelli
SENIOR VICE PRESIDENT
925.997.2307
Adria@LockeHouse.com
License #01498795

Clayton Valley Shopping Center, Concord

Building 5420 - Suite 012D, 1,330 SF



Suite 012D (On Door #40) - Building 5420
Size: 1,330 SF

- **YouTube** Walk-Thru Video: <https://youtu.be/JEKxkfS1fKQ>
- Single Door Entry
- Former Tile Store
- Rear Access
- Includes 1 Restroom (Not ADA)
- 19'.5" Frontage x 68'.11" Depth

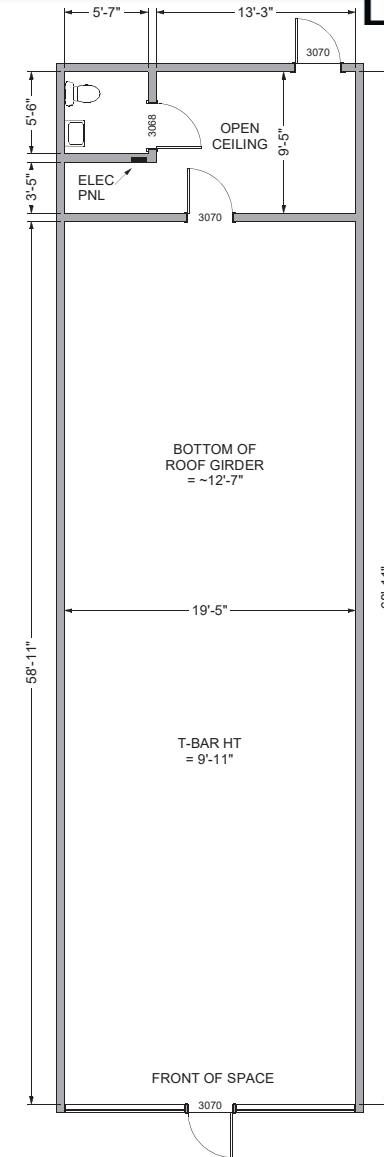
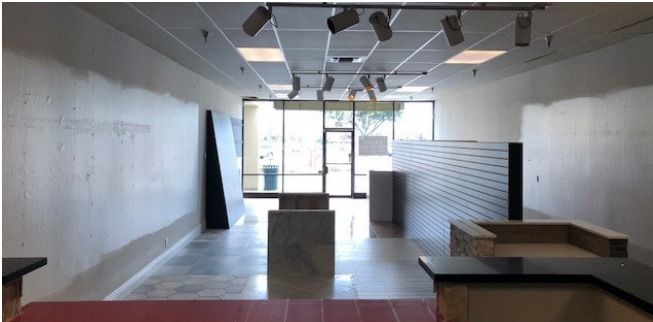

5404-5458 Ygnacio Valley Road | Concord, CA 94521

LOCKEHOUSE
2099 Mt. Diablo Blvd., Suite 206
Walnut Creek, CA 94596
License #01784084



**Regency
Centers.**

Adria Giacomelli
SENIOR VICE PRESIDENT
925.997.2307
Adria@LockeHouse.com
License #01498795

Clayton Valley Shopping Center, Concord

Close-Up Market Aerial



5404-5458 Ygnacio Valley Road | Concord, CA 94521

LOCKEHOUSE

2099 Mt. Diablo Blvd., Suite 206
Walnut Creek, CA 94596
License #01784084



Regency Centers.

Adria Giacomelli
SENIOR VICE PRESIDENT
925.997.2307
Adria@Lockehouse.com
License #01498795

Clayton Valley Shopping Center, Concord

Market Aerial - Surrounding Centers



5404-5458 Ygnacio Valley Road | Concord, CA 94521

LOCKEHOUSE

2099 Mt. Diablo Blvd., Suite 206
Walnut Creek, CA 94596
License #01784084



Regency
Centers.

Adria Giacomelli
SENIOR VICE PRESIDENT
925.997.2307
Adria@LockeHouse.com
License #01498795

Clayton Valley Shopping Center, Concord

Property Photos & Location



5404-5458 Ygnacio Valley Road | Concord, CA 94521

LOCKEHOUSE
2099 Mt. Diablo Blvd., Suite 206
Walnut Creek, CA 94596
License #01784084



Regency
Centers.

Adria Giacomelli
SENIOR VICE PRESIDENT
925.997.2307
Adria@LockeHouse.com
License #01498795

Clayton Valley Shopping Center, Concord

Location and Demographics



DEMOGRAPHICS 2016	1 Miles	3 Miles	5 Miles	10 Miles
Total Population:	16,600	59,950	165,156	546,722
Daytime Population:	3,155	8,670	41,398	210,319
Population Family:	86.3%	87.1%	85.6%	84%
Est. Average HH Income:	\$108,834	\$119,914	\$105,531	\$110,084
HH Income \$100,000 or More:	45.3%	51%	43%	42%
Est. Average HH Net Worth:	\$1,321,486	\$1,487,197	\$1,293,887	\$1,292,790
Bachelors Degree or Higher:	39%	42%	39%	41%
Average Commute Time:	25.5 minutes	25.7 minutes	26 minutes	26 minutes
Annual Retail Expenditure:	\$211 M	\$799 M	\$1.93 B	\$6.77 B



5404-5458 Ygnacio Valley Road | Concord, CA 94521

LOCKEHOUSE
 2099 Mt. Diablo Blvd., Suite 206
 Walnut Creek, CA 94596
 License #01784084



**Regency
Centers.**

Adria Giacomelli
 SENIOR VICE PRESIDENT
 925.997.2307
 Adria@LockeHouse.com
 License #01498795